

Atmospheric Plasma Spray Solutions

March 2016



Plasma

An Advantageous Combination of Versatility and Value

Introduction

By far the most versatile thermal coating process, plasma spray produces high-performance coatings with workhorse durability and reliability.

Plasma, the fourth state of matter, occurs naturally in the sun, star, auroras and lightning bolts. The extremely high temperatures associated with plasma makes it possible to melt or vaporize any known substance in the universe. So it is no surprise that the introduction of the plasma spray coating process in 1960 was a revolutionary moment in the

history of thermal spray. The quality of plasma-applied coatings far surpassed those previously available and swelled the variety of surface functions that could be successfully addressed using thermal spray coatings.

Since the beginning, Oerlikon Metco has been at the forefront of plasma spray technology. Our ever-expanding portfolio of innovative products and services, and the knowledge we bring, meet and exceed the expectation of our customers for surface technology excellence and value.

Optimum Materials...



Innovative Technology...



Perfect Coatings...

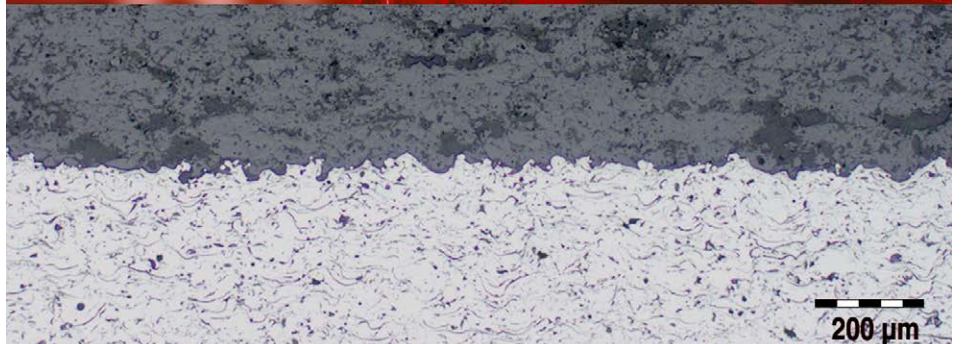

It's the performance and value package you've been looking for!

Proven Flexibility for the Greatest Range of Surface Functionality

Applications

The atmospheric plasma spray (APS) process can apply the widest variety of coating materials, by far, of any thermal spray process. APS performs where other processes cannot with an unlimited coating applications on metallic substrates.

- Manufacture components that exhibit specific surface characteristics.
- Use less costly substrate materials for components, yet maintain high performance surface properties.
- Improve component service life.
- Repair existing components to like-new condition.
- Salvage mismachined components.

Regardless of your need, our aim is to give you a competitive edge in today's tough market environment.

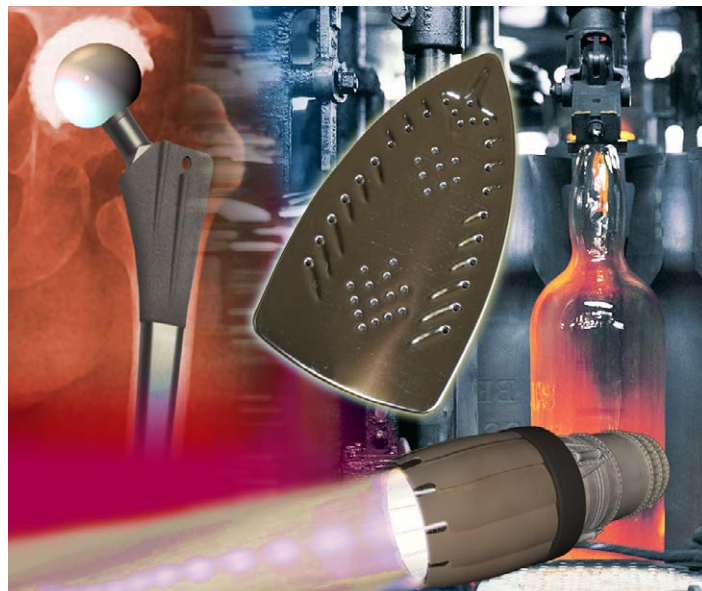

Surface Functionality Achieved with Atmospheric Plasma Spray

- Clearance control between dynamic components
- Abrasive surfaces
- Salvage and restoration of worn surfaces
- Resistance to abrasive, adhesive, fretting or sliding wear
- Cavitation resistance
- Corrosion resistance in acidic, alkaline and saline environments; resistance to chemical attacks
- Hot corrosion resistance
- Electrically conductive surfaces
- Electrically insulative surfaces
- Resistance to chemical attack
- Erosion resistance
- High friction and anti skid surfaces
- Impact resistance
- Low friction and lubricious surfaces
- Oxidation resistance
- Thermally conductive surfaces
- Thermally resistant surfaces
- Decorative treatments

Many industries around the globe have successfully used Oerlikon Metco APS Solutions. Here are just a few:

Aerospace	Gas Turbine and Airframe Components
Automotive and Transportation	Engine and Drive Train Components, Mould Release Coatings
Power Generation	Gas Turbine Components and Cases, Hydroelectric Turbine Components, Steam Turbine Components, Solid Oxide Fuel Cells
Pulp, Paper and Printing Machinery	Anilox Rolls, Impression Rolls, Corona Rolls, Boilers, Digesters, Paper Manufacturing Rolls and Components
Metal Processing	Sink Rolls, Extrusion Rolls, Extrusion Dies
Petrochemical	Pump Components, Valves, Tank Linings
Electronics	RF Shielding, Insulators, Silicon Chip Production Equipment
Textile Machinery	Stretch-Tow Rollers, Thread Guides
Marine	Anti-Fouling Coatings, Anti-Skid Decking, Propellers, Shafts
Consumer Products	Household Irons, Pans, Pens
General Industry	Many surface restoration and functional surface applications

Plasma, the Fourth State of Matter, Is the Foundation of the Process

Process

The flexibility of the plasma spray process comes from its ability to develop sufficient energy to melt almost any coating feedstock material in powder form. The plasma gun utilizes a chamber with one or more cathodes (electrodes) and an anode (nozzle). With process gases flowing through the chamber, direct current power is applied to the cathode, which arcs to the anode. The powerful arc strips the gas molecules of their electrons to form a plasma plume. As the unstable plasma ions recombine back to the gaseous state, a tremendous level of thermal energy is released. The feedstock material is injected into the hot gas plume, where it is melted and propelled towards the target substrate to form the coating.

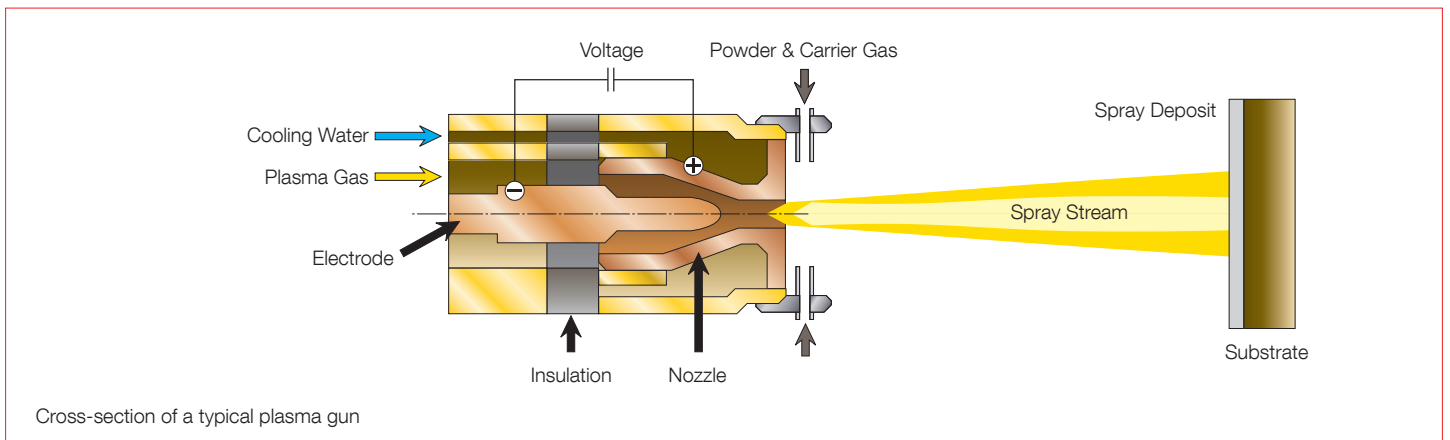

The process gases typically used are argon, hydrogen, nitrogen and helium, either individually or in mixtures of two, or even three of these gases. The gases used in combination with the current applied to the electrode controls the amount of energy produced. Since gas flows and the applied current can be accurately regulated, repeatable and predictable coating results can be obtained. In addition, the shape and bore size of the nozzle, the point and angle that the material is injected into the plume, as well as the distance of the gun to the target surface are also controlled. This provides a high degree of flexibility to develop reproducible parameters for materials with melting temperatures across a very large range.

The distance of the plasma gun from the target components, the relative motion of the spray gun and target component to each other, as well as part cooling — usually as air jets focused on the target substrate — keep the substrate at a controlled temperature in the range of 38 °C to 260 °C (100 °F to 500 °F).

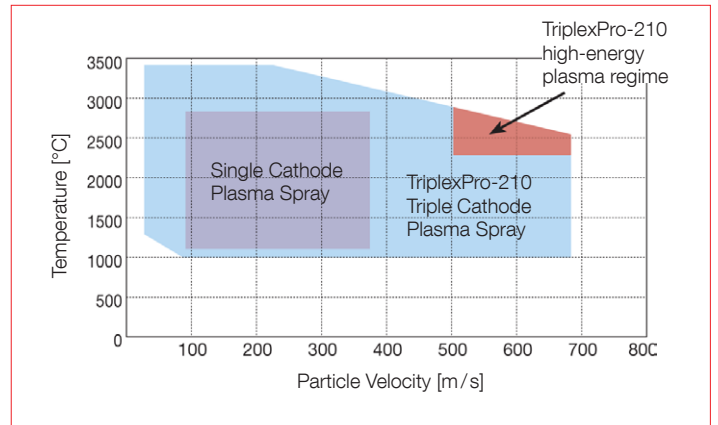

This particle temperature vs. particle velocity diagram shows the broad operational range of the plasma spray process. The extended range of the TriplexPro-210 (blue) includes a high-energy regime (red).



Plasma, the Fourth State of Matter, Is the Foundation of the Process

Process

Triple-Cathode, Cascading Arc Technology: Your ultimate choice for efficiency and reliability

The triple-cathode, cascading arc spray gun represents the latest technology in plasma spray. The key features of this technology are:

- Higher voltage levels developed with reduced current input
- Fixed arc lengths
- Arc behavior that is independent of gas type or flows

This results in unsurpassed plasma plume and process stability, the ability to extend the operational region of plasma spray, higher material throughput (based on deposit efficiencies and spray rates), and the capability of long spray campaigns without the need to change internal gun components.

Single Cathode, Cascading Arc Technology: Economically improve your plasma spray process efficiency

The single-cathode, cascading arc spray gun is an excellent upgrade choice for existing plasma spray systems. It is a low-risk, high-reward approach to improving plasma process efficiency with minimal investment.

- Stable plasma arc across a wide range of gas flows, gas mixtures, and pressures
- Sprays all types of powder materials
- High throughput increases productivity
- Easily retrofits into existing plasma spray systems
- Available in 90° and 180° models

Conventional Arc, Single Cathode Spray Gun Design

Key features of the single cathode spray gun design are:

- Technology proven over five decades by thousands of customers globally in many different industries
- A slightly lower initial capital investment
- The availability of extension guns to coat small internal bores

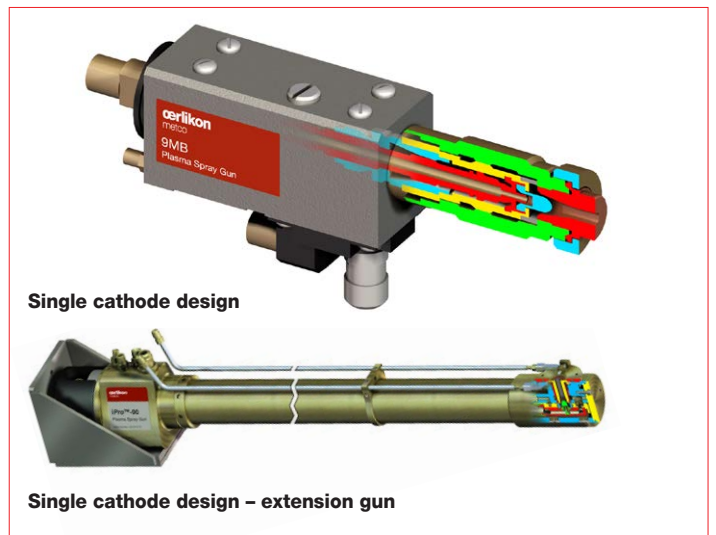
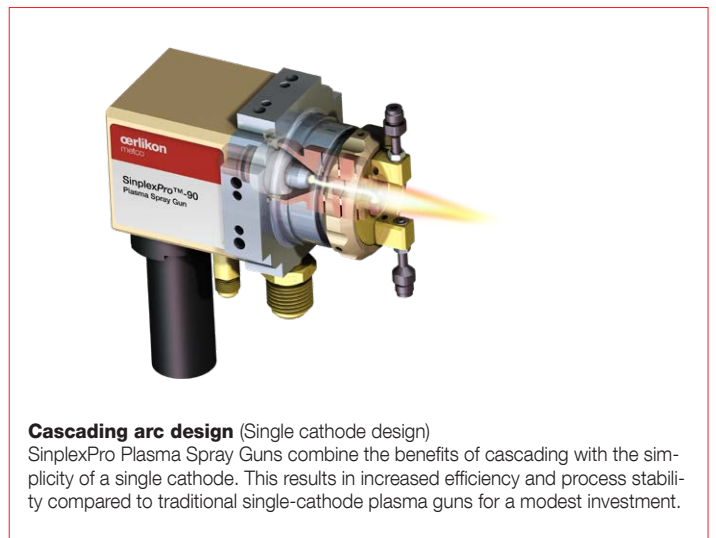
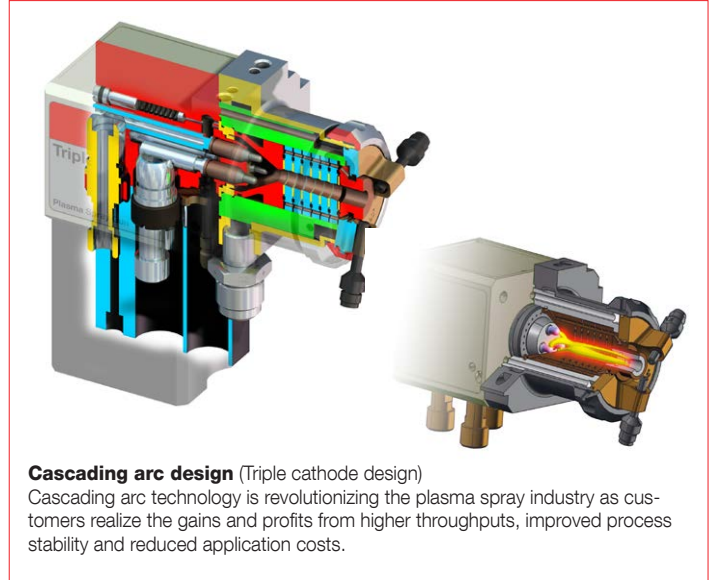

Modern Material Manufacturing and Process Control Are Key

Characteristics

More than ever, the state of the art methods used to manufacture the coating materials used for atmospheric plasma spray and the level of process control employed in today's coating equipment provides excellent coating reproducibility over a broad range of application requirements.

Each possible characteristic depends on the coating material, spray equipment configuration, spray parameters and component configuration — and many characteristics for specific applications are not mentioned here.

- **Controlled Porosity.** Coating porosity levels can be controlled to less than one percent, and in some cases, post-coating processes such as diffusion heat treatment or fusion can achieve full density. In other applications, such as thermal barrier coatings, the required higher porosity levels can be as high as 20 percent.
- **Optimized Hardness.** Hardness levels can range from quite soft (40 RH), which may be required for certain clearance control or interference fit applications, to very hard (macrohardness of 70 RC and microhardness of 1200 DPH300), to meet the demanding requirements of a wear resistance application.
- **Specific Coating Thickness.** Coating thickness can be tailored to as thin as 0.075 mm (0.003 inches) to as thick as 5 mm (0.2 inches).
- **Good Bond Strength.** Coating bond strengths range from 17 MPa (2,500 psi) for some soft alloys such as copper, to greater than 83 MPa (12,000 psi) for some carbide materials, ensuring that plasma-sprayed coatings will be durable in service.
- **No Heat-Affected Zone.** Because plasma-sprayed coatings are applied as small, individual molten particles that cool and solidify instantaneously, there is no heat-affected zone between the coating and the substrate material, minimizing or eliminating any possible fatigue debit. This feature also allows components to be stripped and recoated multiple times.
- **No Component Distortion.** Motion parameters (spray gun and target component motion) and cooling combine to maintain substrate temperatures well below a temperature that could cause distortion of the coated component.
- **Wide Choice of Surface Finishes.** If surface finish is not critical, plasma-sprayed coatings can be used in the 'as-sprayed' condition. However, many coatings can be machined, ground, lapped or honed to produce excellent surface finishes, precise dimensional control and specific finish requirements. Other coatings can be sprayed with a very coarse or rough surface finish for applications where an abrasive or anti-skid surface is needed.
- **Tailored Coating Systems.** Several coating materials can be applied to form an integral coating system. For example, a bond coat may be chosen that is compatible in chemistry or thermal expansion coefficient with the substrate material and over-coated with another material that has other desirable surface properties.
- **Complex Geometries.** The range of plasma spray guns available, combined with an endless variety of gun and component handling mechanisms allow the coating of very complex geometries and even deep internal bores as small as 30 mm (1.2 inches) in width.

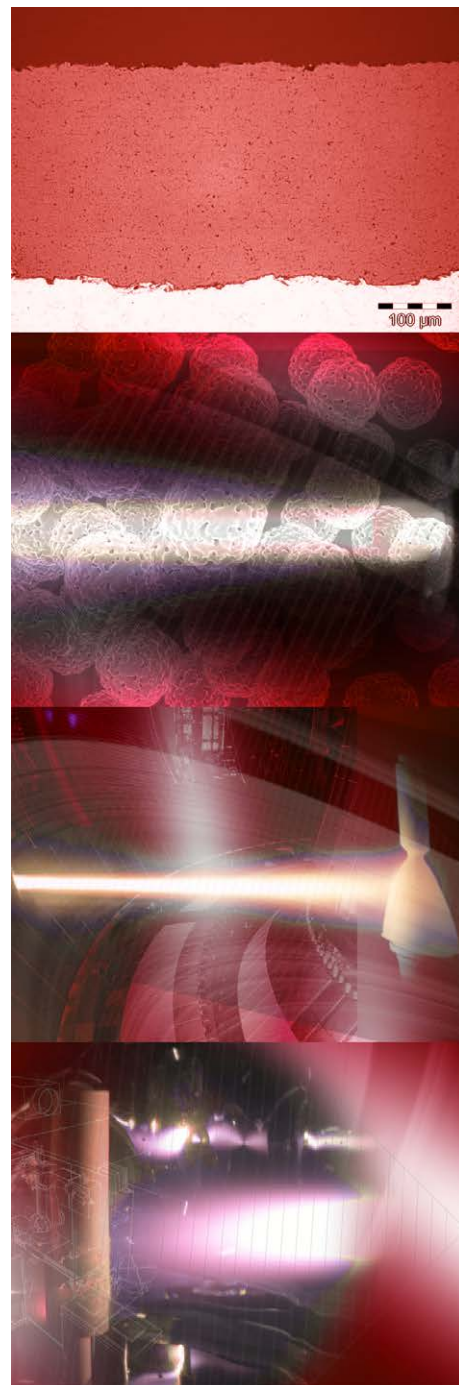

Building Blocks of a Successful Atmospheric Plasma Spray Solution

Key Elements of an APS Solution

Core Components

Core elements are required for all plasma spray solutions. These include the coating material to be applied, a powder feed delivery system, the atmospheric plasma spray gun to heat the coating material and propel it to the workpiece, a control system that accurately controls the gas, electrical and cooling water requirements, and a power supply to convert incoming AC power to the appropriate DC power required by the spray gun. A heat exchanger is also required to cool the spray gun.

Handling Components

In all but the most simple of manual spray systems, handling equipment precisely controls the movement of the spray gun and workpiece, and their relative position to one another.

Peripheral and Auxiliary Components

A soundproof cabin as well as an air filtration and exhaust system protect booth personnel and the environment. In addition to the core heat exchanger, a water chiller may be required to ensure efficient gun cooling. Often, it is necessary to have cooling air to control the temperature of the workpiece. For the most advanced process control, spray plume monitoring and diagnostics are recommended.

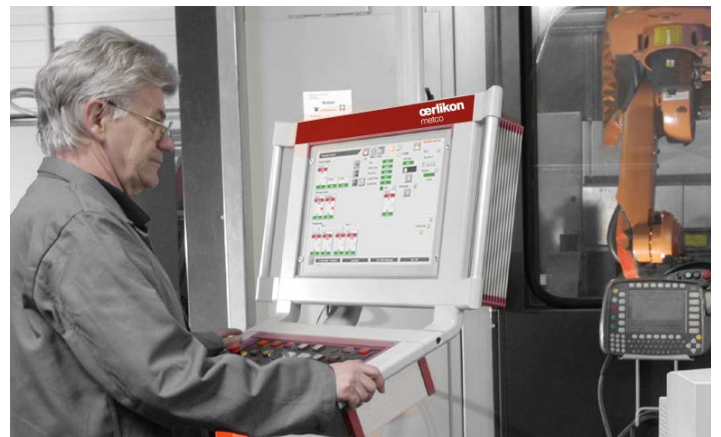
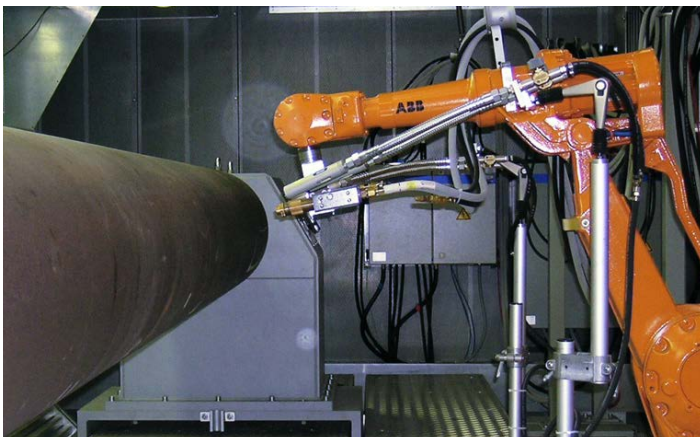
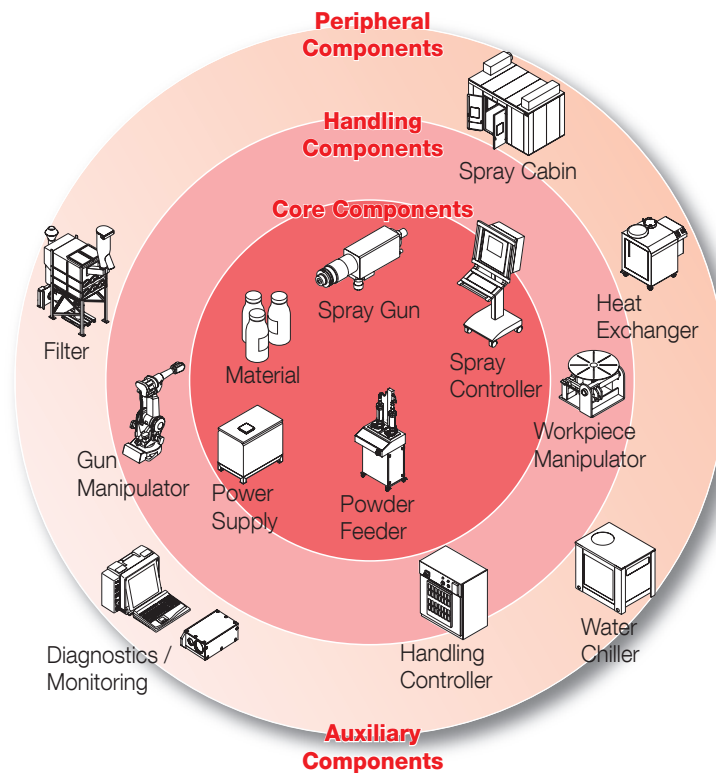

Every Successful Application Starts with the Right Material Choice

Materials

Oerlikon Metco offers an extraordinarily diverse portfolio of materials for the atmospheric plasma spray process, each capable of achieving one or more surface functions. Our material engineering, sourcing and manufacturing expertise is unequaled in the thermal spray industry.

Our specialists can work with you to choose the ideal material for your application. The selection of powders we offer for the atmospheric plasma process includes:

- Pure metals
- Alloys and superalloys
- Metallic blends and composites that alloy during the spray process
- MCrAlY materials comprised of nickel, cobalt, iron or combinations of those metals alloyed with chromium, aluminum and yttrium.
- Cermets used to reduce thermal mismatch between the substrate and a ceramic topcoat
- Carbides
- Self-fluxing alloys which can subsequently be fused to create fully dense coatings
- Abradable materials, which are blends or composites of metal alloys and various second and third phases, are tailored to provide optimal performance in gas path sealing applications.
- Ceramics

To further accommodate specific customer requirements, many of our powder materials come in several particle size distributions.

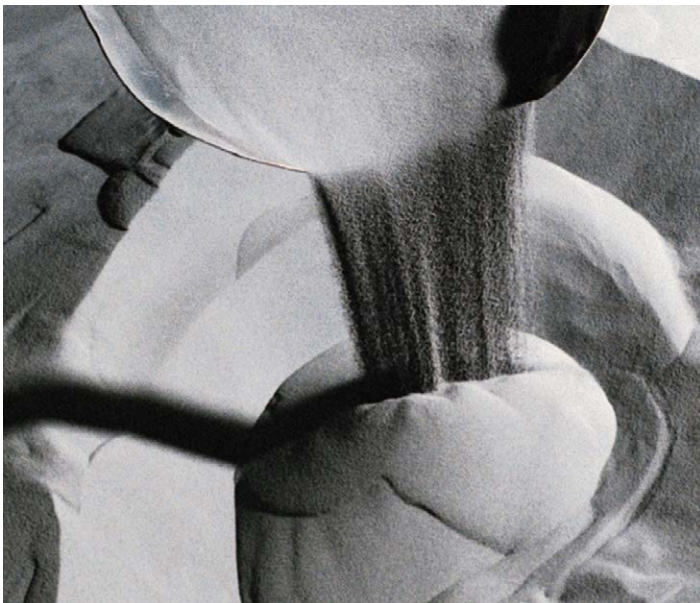

Atmospheric Plasma Spray Powders

Materials

Common Classes, sorted by Chemistry

Material Class ¹		Abradables					Pure Metals, Alloys, Superalloys, MCrAlY's, Composites, Blends							Carbides		Ceramics				Self-fluxing		
Base element:		Al	Co	Cu	Ni	ZrO ₂	Al	Co	Cu	Fe	Mo	Ni	Ti	Cr	W	Al ₂ O ₃	Cr ₂ O ₃	TiO ₂	ZrO ₂	Co	Ni	
Electrical	Insulation															◆		◆				
	Conductance						◆		◆													
Thermal	Thermal Barrier/Insulation																		◆			
	Conductance						◆		◆													
	Oxidation Resistance							◆				◆				◆						
Dimensional	Salvage/Restoration						◆	◆	◆	◆		◆										
	Bond coat							◆				◆	◆									
	Clearance – Abrasive															◆	◆					
	Clearance – Abradable	◆	◆	◆	◆	◆																
Wear Resistance	Erosion									◆	◆	◆		◆	◆	◆			◆	◆	◆	◆
	Fretting							◆	◆			◆		◆	◆		◆	◆	◆	◆	◆	◆
	Abrasion										◆	◆		◆	◆	◆	◆	◆		◆	◆	◆
	Impact/Bearing								◆		◆			◆	◆						◆	◆
	Adhesive								◆	◆	◆			◆	◆		◆	◆				
	Sliding							◆		◆	◆	◆		◆	◆	◆	◆	◆				
	Cavitation								◆	◆		◆			◆		◆			◆	◆	◆
	Saline						◆	◆	◆			◆										
Corrosion Resistance	Acidic							◆			◆					◆	◆					
	Alkaline										◆					◆	◆					
	Chemical Attack									◆	◆	◆					◆					
	Hot Corrosion							◆				◆							◆			
	Service Temperature Range ²																					

¹ Coatings of a specific material product in a specified category may not offer all surface functionality shown. Consult with Oerlikon Metco for the best choice for your application.

² Temperature range depends on the exact material chemistry chosen and other application considerations. Specific materials may not be serviceable in the full range indicated.

Ensure the Success of Your Application with the Right System

Core Systems

Our staff of dedicated thermal spray professionals and the range of equipment choices for the atmospheric plasma spray process we can offer to you is your guarantee we can provide a thermal spray system that is perfect for your coating processing needs. Here you will see just a few examples of our APS core equipment technology



Oerlikon Metco 9MC Semi-Automatic Plasma Spray System:

- Ideal for smaller spray shops with moderate surfacing needs
- Semi-automatic operation for accurate and repeatable coatings
- Programmable Logic Control (PLC) with rotameter gas metering system

- Built-in monitoring and alarm system with automatic shut-down for safe operation
- Interfaces for workpiece handling equipment, gun manipulators, exhaust system and accessories
- Diagnostic display panel
- Customize your system with gun and part manipulation equipment ideal for your spray applications

Ensure the Success of Your Application with the Right System

Core Systems



Oerlikon Metco UniCoatPro™ Plasma Automatic Plasma Spray System:

- Ideal for small shops with broad range of surfacing needs or medium to large shops with high-volume surfacing needs and increased quality control requirements
- Fully-automatic operation for highly accurate and repeatable coatings
- Programmable controller with mass-flow control gas metering system

- User friendly, color touch-screen programming with storage for 100 recipes
- Advanced diagnostics, monitoring and control with alarm system and automatic shutdown for safe operation
- Sophisticated trending and reporting
- Interfaces for exhaust, chiller, spray booth and fully featured handling interface by an external controller
- Customize your system with gun and part manipulation equipment

Ensure the Success of Your Application with the Right System

Core Systems



Oerlikon Metco MultiCoat™ Advanced Plasma Spray System:

- The most advanced system platform on the market!
- Ideal for medium to large shops with many different surfacing needs, R&D facilities, and moderate to high-volume production needs
- Configurable for multiple spray processes including atmospheric plasma spray, gas fuel HVOF, liquid fuel HVOF, combustion powder and wire spray – all of which can be controlled from a single controller
- Fully-automatic operation for highly accurate and repeatable coatings
- Twin-Brain design with PC-based operator console and Programmable Logic Control (PLC) based controller with mass-flow control gas metering system
- User friendly, color touch-screen programming with storage for 1000 recipes
- Advanced diagnostics, monitoring and control with multi-level alarm system and automatic shutdown for safe operation
- Digital data bus interfaces for workpiece handling equipment, gun manipulators, exhaust system and accessories
- Use any Oerlikon Metco plasma spray gun
- Diagnostic display panel
- Customize your system with gun and part manipulation equipment ideal for your spray applications

Tools of the Trade to Get the Job Done Right

Plasma Spray Guns

Oerlikon Metco offers the largest selection plasma spray guns in the industry, so our customers can choose the ideal tool for their specific coating and production requirements. Our spray guns are the choice of thousands of customers worldwide, and are renowned for reliable and consistent performance.

TriplexPro™-210

Unsurpassed value for the 21st century

- Up to 90 kW power capability
- Cascading arc, triple cathode
- Maintains constant coating quality for hundreds of hours without the need to adjust parameters
- Up to 200 hours of nozzle and electrode life at 60 kW
- High Spray rates of up to 200 g/min (26.5 lbs/hr) assure lowest operational costs per unit of material applied
- Typical deposit efficiency gains of 10 to 20 percent over traditional plasma spray guns
- Control plasma plume shape with exchangeable nozzles

SinplexPro series

- Up to 60 kW power capability
- Cascading arc, single cathode
- Recommended to improve throughput efficiency of existing plasma spray systems
- High spray rates up to 120 g/min (16 lb/hr)
- Excellent process stability and coating quality

F4MB-XL series

The ultimate single cathode plasma spray gun

- Up to 55 kW power capability
- Excellent stability with only minor parameter adjustments required
- Long, reliable nozzle and electrode life
- Spray rates of up to 100 g/min (13.25 lbs/hr) assure excellent operational costs per unit of material applied
- Narrow plume assures dense, well-structured coatings
- Particle velocities of up to 380 m/s (1250 ft/sec)

3MB

50 years of reliable plasma spray service

- Up to 40 kW power capability
- Inexpensive quick-to-change nozzle and electrodes assure the correct parameter every time
- Broad plume shape assures excellent coating thickness control, even when hand spraying
- Small overall size goes into tight locations
- Low capital cost



Tools of the Trade to Get the Job Done Right

Plasma Spray Guns

iPro-90

High power plasma extension gun

- The highest power plasma extension gun in the industry!
- Power capability up to 90 kW
- Coat internal bores as small as 150 mm (6 Inches) and 600 mm (2 feet) depth
- Robust design for high volume production and long spray runs

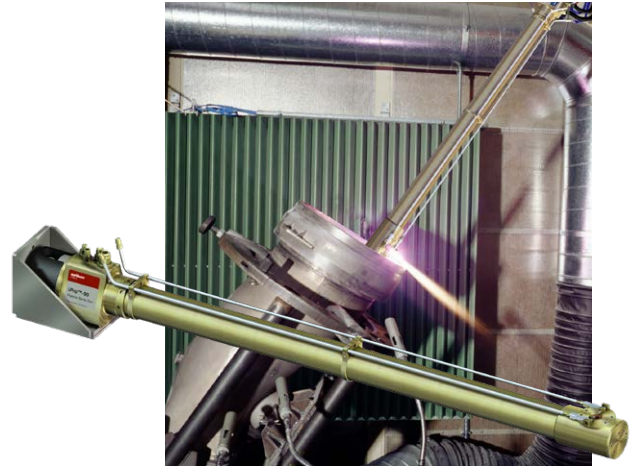

SM-F220

Modular plasma extension gun

- Coat internal bores as small as 85 mm (2.4 inches)
- Efficient 16 kW power capability that applies high quality coatings, including ceramics
- Fast changeover of the complete gun head
- Revolutionary, built-in air jet system eliminates the need for external air jets
- Superior gun cooling system extends uptime and reduces maintenance costs
- Excellent deposition efficiency and throughput
- Designed for high volume production

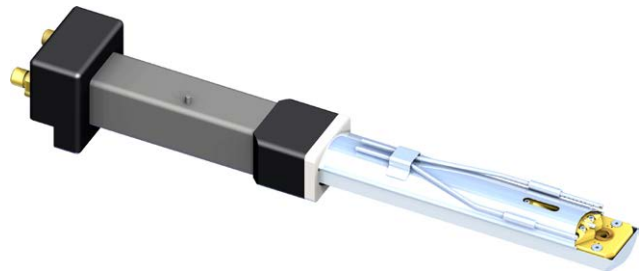

SM-F210

Modular plasma extension gun

- Coat internal bores as small as 60 mm (3.3 inches)
- Efficient 16 kW power capability that applies high quality coatings, including ceramics
- Excellent deposit efficiencies and spray rates
- Modular design with simple changeover for different lengths, hose and cable connection arrangement and spray angle
- Unique built-in air jets eliminates the need for external cooling jets
- Configure with internal or external powder feed



Does your application require a specialized spray gun? These represent only some of products in our plasma spray gun portfolio. Most likely, we have the ideal spray gun for your application. We also have a wide variety of options for our plasma spray guns, such as specialized nozzle configurations, powder injectors, injector holders and air jets.

Precise Material Feed Is Not an Art, But a Science

Powder Feeders

At first glance, the concept of moving the powder feedstock material from the reservoir or 'hopper' to the gun may seem to be a simple process, but in fact, a great deal of know-how is required. The powder particle size distribution used for plasma spray is generally fine, so any moisture that may cause clumping must be avoided. Furthermore, to insure

uniform and repeatable coating results, a constant feed rate, without pulsation, is needed.

Oerlikon Metco offers two material feeding technologies, each engineered to provide excellent results for your plasma spray system

Fluidic Powder Feeders

This technology combines gravity, fluidization of the powder in the hopper and a pressure differential to deliver the material to the spray gun. An increase in pressure differential increases the powder feed rate.

9MP Powder Feeder

The ultimate level of powder feed control

- True, closed-loop feed rate control continually monitors the weight of the hopper system and adjusts material feed rate to within ± 1 g/min
- Self-calibrating and self-teaching software eliminates the need to perform manual feed rate checks
- Large, easily cleaned powder hoppers
- Digital interface with direct input of feed rate and local indication of carrier gas flow rate and pressure

5MPE Powder Feeder

Basic, affordable powder feed capability

- Open loop design maintains feed rate to within ± 5 g/min
- Uses the same advanced fluidic pickup shaft and large hopper assembly to control flow and large, easily cleaned hopper assembly as the 9MP series feeders
- Simple operation
- Easily moved between booths
- Optional PFRM Feed Rate Meter available

Volumetric Powder Feeders

The volumetric feed technology incorporates gravity feed into a grooved, rotating disk to deliver a precise quantity of powder. An increase in disk speed increases the powder feed rate.

Twin/Single Series Powder Feeders

Excellent feed control in an easy to use package

- Closed loop control of disk and stirrer speed maintains feed rate to within ± 2 g/min
- Rapid start/stop, quickly achieves feed rate set point
- Stirrer minimizes powder segregation
- Easily exchanges hoppers can store excess material or be used for specific materials to prevent cross-contamination
- Twin models feed both top and bond coat materials
- Models with powder feed rate control available
- Many models have 2 hoppers, which can be used independently or together for even higher feed rates.

Twin150 Series Powder Feeder

Versatile and accurate powder feeder that can be used as a stand-alone unit

- Operates in standalone, remote on/off, full remote or PROFIBUS modes
- Mass flow controlled carrier gas
- Precise volumetric feeding system
- Easy to use touchscreen interface
- Powder hoppers can be operated independently with different parameters

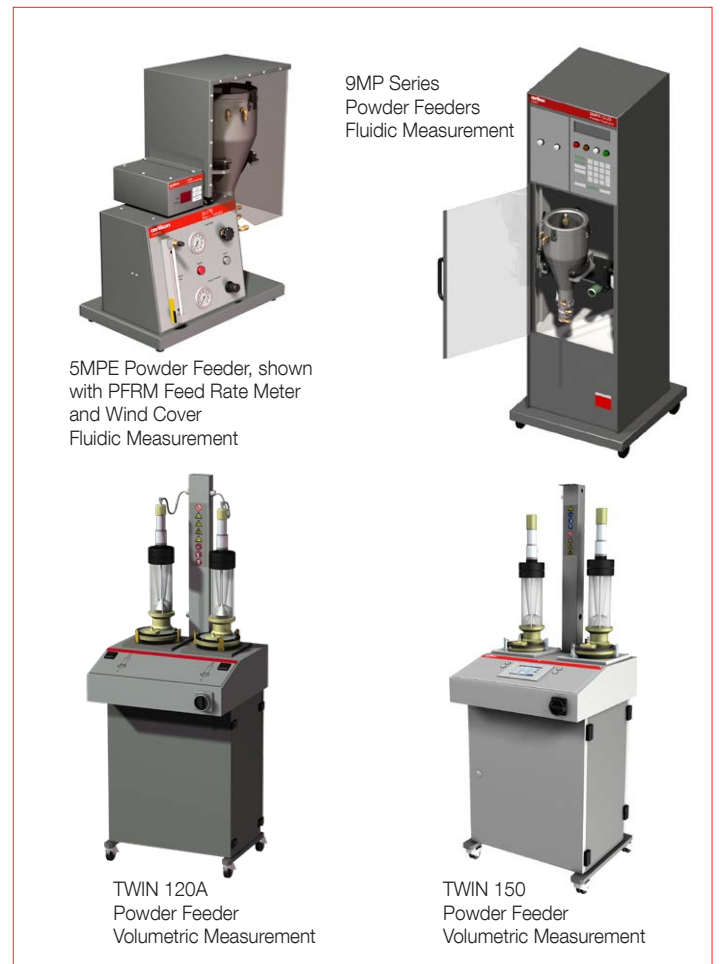

The Linkage of the Coating Process to the Component

Handling Equipment

Once the coating material has been chosen and the core system technology selected, the spray gun and component manipulation system must be designed to achieve maximum production efficiency and repeatability. Oerlikon Metco's

system engineers have the experience you need to design effective handling systems, even complex systems involving many coordinated axes.

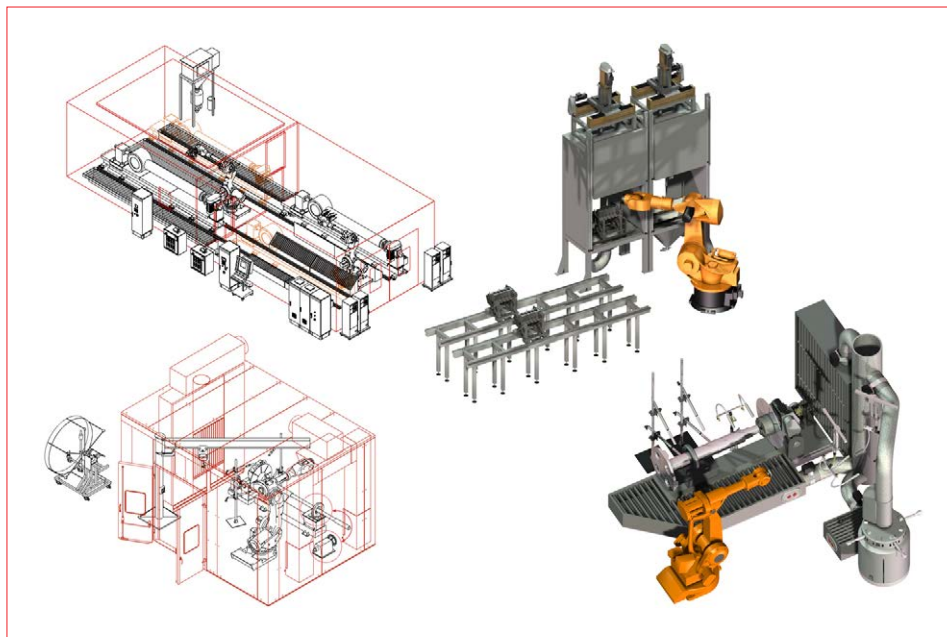

Do you have a component that is either too heavy to rotate easily or not rotationally symmetrical? The Oerlikon Metco RotaPlasma™ HS1 is the solution!

With innovative system engineering, RotaPlasma HS1 can be designed part of a traverse mechanism, or as a coordinated auxiliary robot axis to coat for non-uniform interior or exterior profiles.

RotaPlasma HS1 is unique in that it rotates the plasma spray gun, instead of your component. Combined with our innova-

RotaPlasma HS1 can make a tough coating application easy.

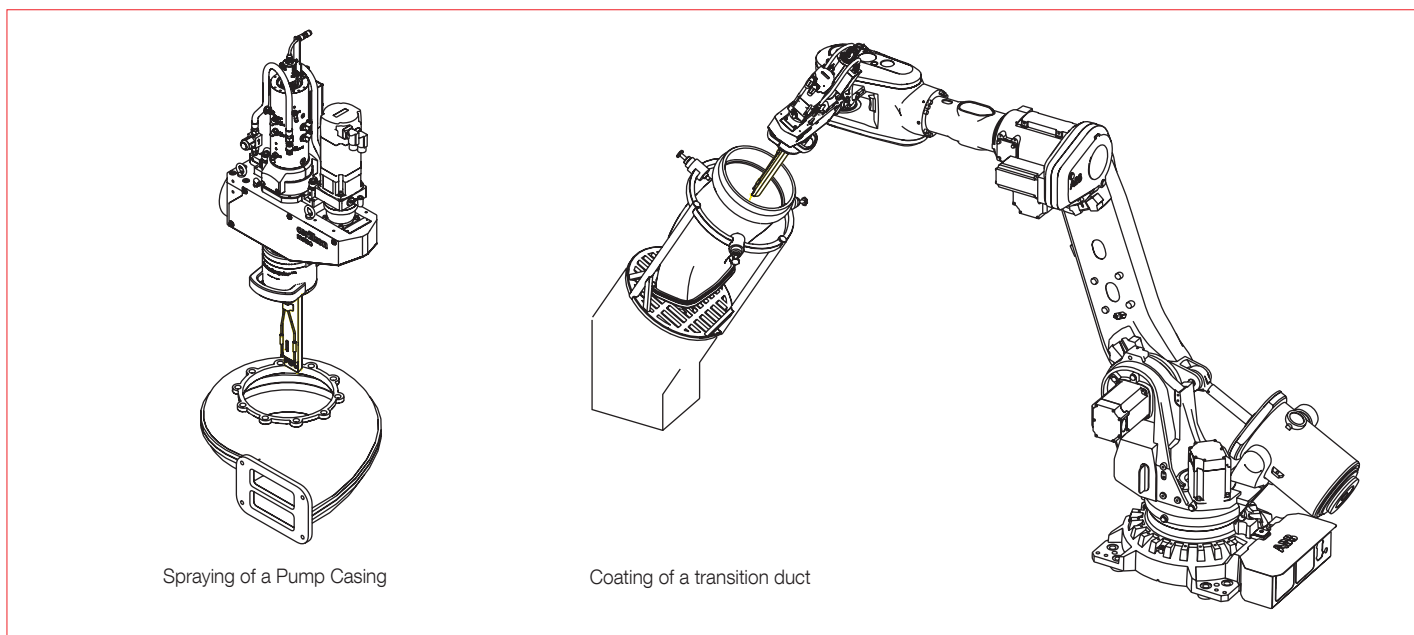

Spraying of a Pump Casing

Coating of a transition duct

The Ultimate Tool for Real-Time Spray Process Control

Diagnostics

Continuous, real-time plume monitoring and diagnostics brings a level of process control only dreamed about just a few years ago. This new technology offers key advantages through monitoring of the spray process to within a precise, pre-defined window of output plume characteristics.

What's more, development time of new spray parameters is significantly reduced using spray plume monitoring and diagnostics because particle and plume characteristics are measurable, enhancing spray parameter process mapping.

Real-time measurement of:

- Particle velocity and temperature
- Spray plume intensity, position and geometry
- Substrate temperature (optional)

Tecnar Automation Ltd. and Oerlikon Metco combine unrivaled knowledge and experience to bring this exciting new technology to our customers.

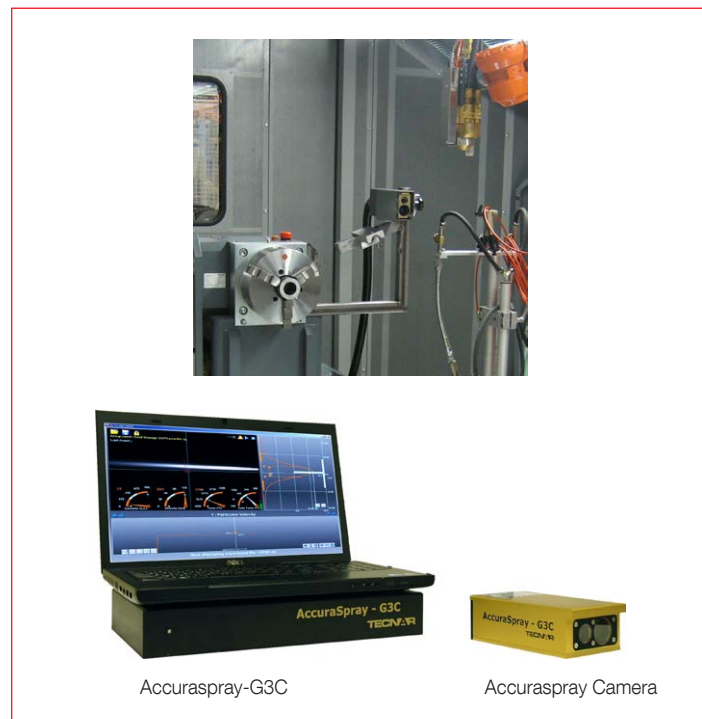

Safety and the Environment Are Core Oerlikon Metco Values

Environment

Safety and environmental control are not simple tasks, but we believe they are the most important aspects of any thermal spray solution. The design of our components and systems meet or exceed the latest codes and standards, and our material SDS (Safety Data Sheets) are written to the

latest requirements of each locale. As part of a Oerlikon Metco coating solution, we consult with you on all the necessary aspects of safety and environmental control to meet your local regulations. This includes air quality and noise control, as well as operator and plant safety.



Intelligent Solutions for Every Application

Solutions

Whether you process a wide range of part sizes and shapes with a variety of coatings or require a dedicated coating solution integrated into your manufacturing line, our team is ready to work with your team. Our experienced and knowledgeable professionals are there for every phase of your coating solution, including initial consultation, proof of concept, system engineering and integration, installation and commissioning of a fully functional solution. And we don't just stop there — Oerlikon Metco is always there with after sales support and service.

A Typical Standard Coating Solution

1. Process controller UniCoatPro Plasma
2. Power supply PT3X
3. Plasma Gun SinplexPro
4. Powder Feeder Twin 140
5. MC Chiller
6. Gun manipulator robot IRB 2600
7. Part manipulator turntable Robax-1000
8. Spray hood standard plenum
9. Sound booth
10. Dust collector OME-0 36-95

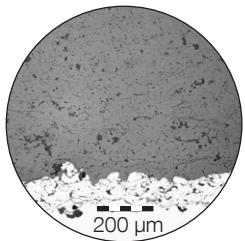
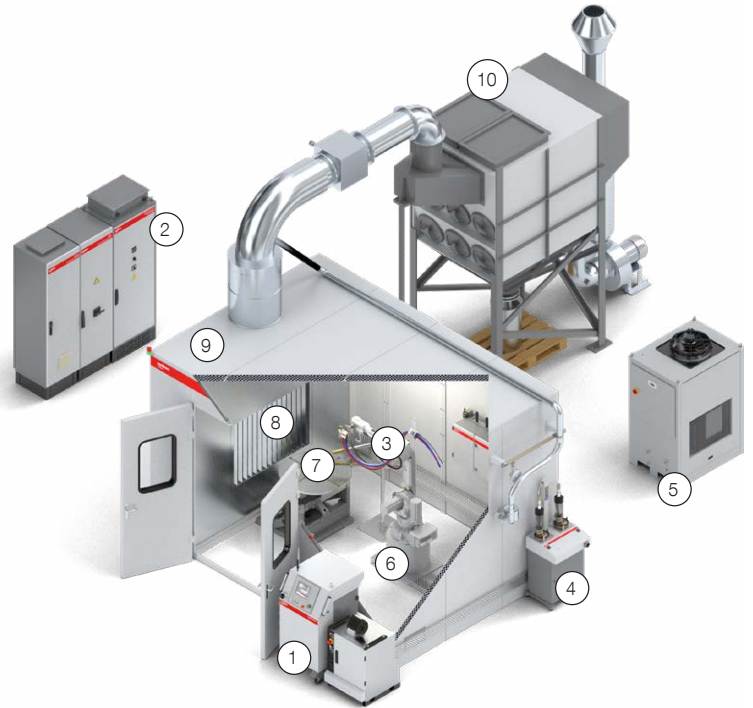

Coating:

Nickel based high temperature bond coat with zirconia-based ceramic top coat for thermal insulation.

A High-End Customized Coating Solution

Fully integrated into the manufacturing production cell

1. Grit blast Station 1
2. Grit blast Station 2
3. Grit blast Treatment
4. Cleaning Station
5. Plasma Spray Station 1
6. Plasma Spray Station 2
7. Plasma Spray Station 3
8. Cooling Station
9. Spray Mask Handling
10. Transport System
11. Operator's Panels
12. Data Management System
13. Water Chillers
14. Gas Management Centers

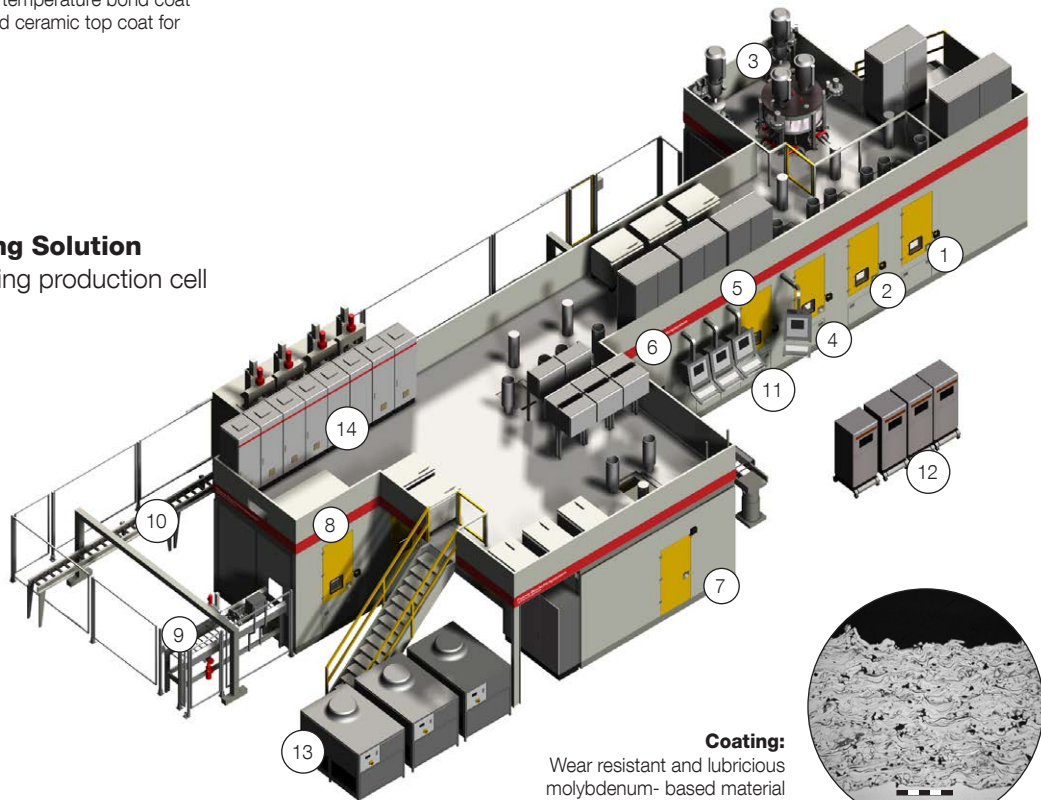

Coating:

Wear resistant and lubricious molybdenum-based material

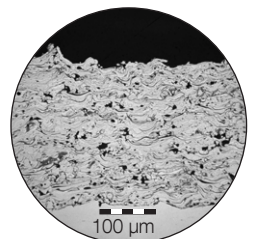

Oerlikon Metco Essential Services for Ongoing Success

Services

Training

Let our staff professionally train your personnel on the safe operation and maintenance of your thermal spray systems.

Field Service

Qualified, factory-trained field service technicians will keep your systems in peak operating condition. Our field services include flexible maintenance contracts, emergency break-down repairs and troubleshooting help.

Traceability

Fully traceable calibrations, including gas flows and pressures, ensure the accuracy and repeatability of your spray facilities.

Application consultation services

Our thermal spray professionals can consult with you for a total application solution with optimized benefits and value.

Consumable and spare parts support

Oerlikon Metco brand consumable and spare parts keep your coating facilities operating with repeatable results.

Simplified sourcing

Simplify your purchasing decisions with Oerlikon Metco quality consumable parts and materials from a single source that can supply all of your plasma spray needs.

Global sales and logistics

Oerlikon Metco professionals are prepared to help, wherever your location.

Make or buy — It's your decision

If you would prefer to outsource your coating work, Oerlikon Metco is ready to serve you. We have first-rate coating facilities on every major continent around the globe. The surface engineering experts at the Oerlikon Metco coating service facility of your choice are ready to consult with you and provide your company with expert coating and machining services.

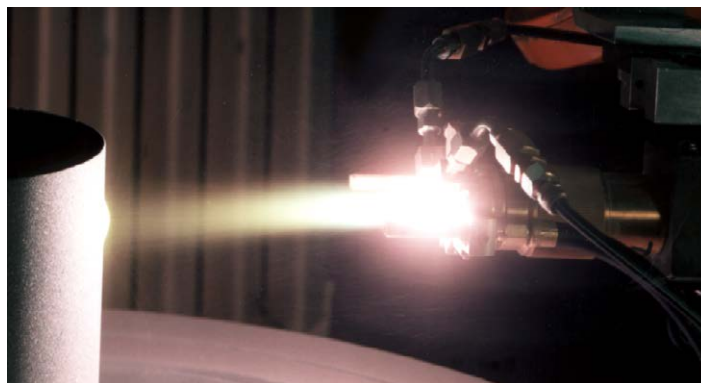

Atmospheric Plasma Solutions

Advanced Technology Solutions and Services



Plasma

Perfect solutions through optimum materials and innovative technologies

Oerlikon Metco is a global leader in surface engineering solutions and services offering:

- A broad range of thermal spray, thin film, laser cladding and other advanced surface technology equipment and materials
- Integrated systems
- Specialized coating and surface enhancement services
- Manufactured components for the turbine, automotive and other industries
- Customer support services

Oerlikon Metco provides a comprehensive manufacturing, distribution and service network, catering to aviation, power generation, automotive and other strategic growth industries.

To take control of your surface engineering challenges, contact your Oerlikon Metco sales office, visit our web site at www.oerlikon.com/metco or e-mail us at info.metco@oerlikon.com.

About Oerlikon Metco

Oerlikon Metco enhances surfaces that bring benefits to customers through a uniquely broad range of surface technologies, equipment, materials, services, specialized machining services and components. The surface technologies such as Thermal Spray, Thin Film, Plasma Heat Treatment and Laser Cladding improve the performance and increase efficiency and reliability. Oerlikon Metco serves industries such as aviation, power generation, automotive, oil & gas, industrial and other specialized markets and operates a dynamically growing network of more than 50 sites in EMEA, Americas and Asia Pacific. Oerlikon Metco, together with Oerlikon Balzers, belongs to the Surface Solutions Segment of the Switzerland-based Oerlikon Group.

Information is subject to change without prior notice.